



## PUN1003. Twisty strip anchor for grooved stone.

It is a punctual anchoring system, made of stainless steel A2/A4, and different sizes (15, 20 or 25 mm width; 2, 3 or 4mm thickness and necessary length).

The wall should be solid for this system and the connection is made by resin or cement mortar.

Simple and efficient installation.

Valid for any kind of facade configuration, it is completely hidden.

Highly recommended for horizontal joint, barely loses strength with increasing length.

The following table indicates the load values for the most requested products of the series.

For any question please contact our technical department in

[letstalk@perfilstoneinnova.com](mailto:letstalk@perfilstoneinnova.com)

Allowables load values (kN) according to anchor dimensions and position.

DIMENSIONS(mm)	LENGTH(mm)	EMBEDMENT(mm)	OVERHANG(mm)	LOAD (kN)
15x3	100	70	30	0,29
15x3	120	80	40	0,29
15x3	130	80	50	0,29
15x3	150	80	70	0,29
15x3	180	80	100	0,29

REF: PUN1003

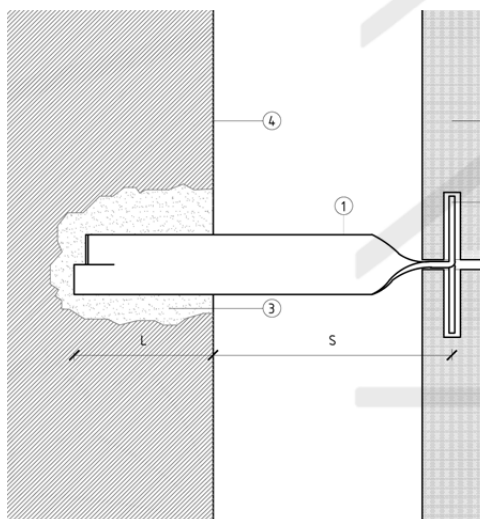

Load values are in kN for maximum deformation of 1,4 mm.

These values relate exclusively to the flexural strength of this system made of stainless steel A2/A4.

The values assume a correct fixation of the system to the wall, so it must be the right for each system. However, it is recommended a test on site.

Both manufacturing and testing are carried out according UNE 41957/1:2000

1. Twisty strip anchor for grooved stone
2. Connection element for grooved stone
3. Resin or mortar
4. Wall
5. Cladding